

4 COLOURS AND/OR MATERIALS

P4C

Layout con due "Modulo 2"; indispensabile per poter iniettare ogni colore/materiale sopra al precedente.

Layout with two "Modulo 2" machine, essential to inject each colour/material over the previous one.

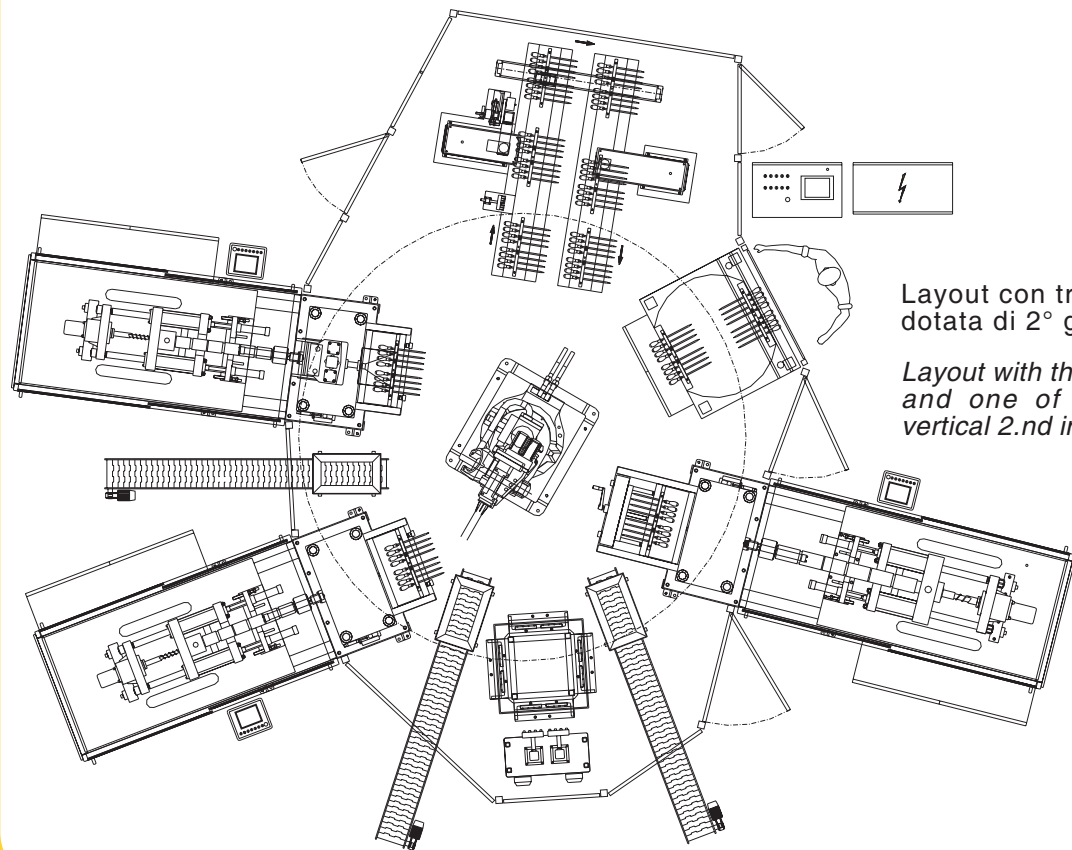
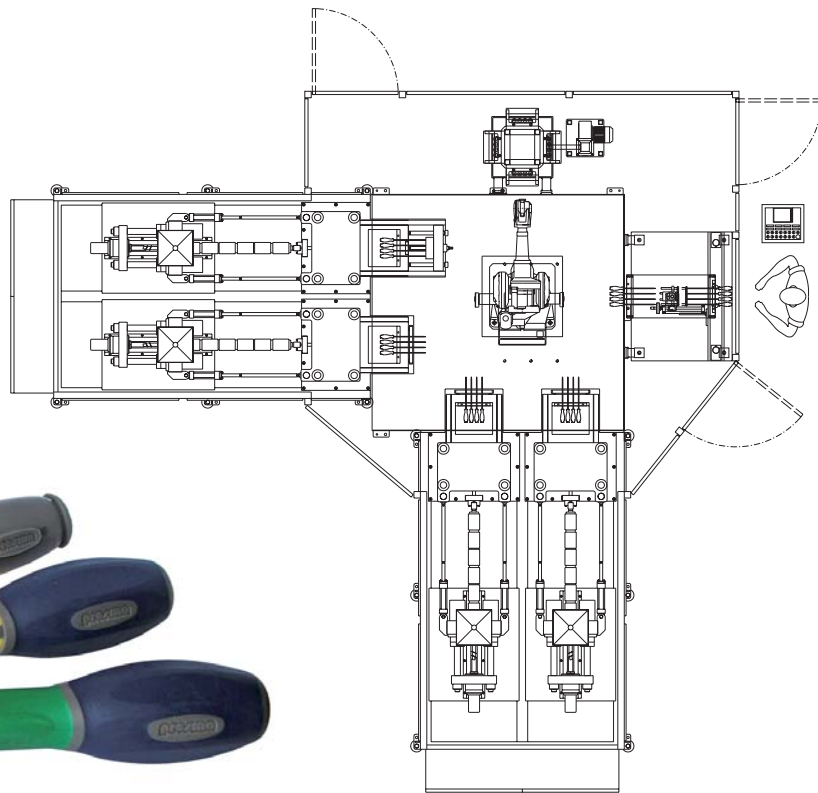

Layout con tre "Modulo" di cui una dotata di 2° gruppo verticale

Layout with three "Modulo" machines and one of them equipped with vertical 2.nd injection unit



Centri di lavoro multistazione

Multi-station Production Cell



P2C



P3C



P4C

Il centro di lavoro multistazione PRESMA è l'ideale per lo stampaggio di articoli multi-componente con inserti. La flessibilità è ottenuta tramite stazioni separate per l'iniezione di ogni componente, raffreddamento, caricamento inserti e controllo finale del pezzo.

Presma multi-station production cell is ideal for multi-component insert moulding. Flexibility through separate stations for moulding each component, cooling, insert loading and final part inspection



Via delle industrie, 8/10 - C.P. 25
21040 Torba di Gornate Olona (VA) Italy
Tel. +39 0331811611
Fax +39 0331820026
e-mail: info@presma.it - www.presma.it

**Non Standard
Technology**
for Thermoplastics and Rubber

P4C_GB



2 COLOURS AND/OR MATERIALS

P2C

Layout con una "Modulo 2" e tavola operatore per carico inserti

Layout with one single "Modulo 2" machine and operator station for inserts loading.

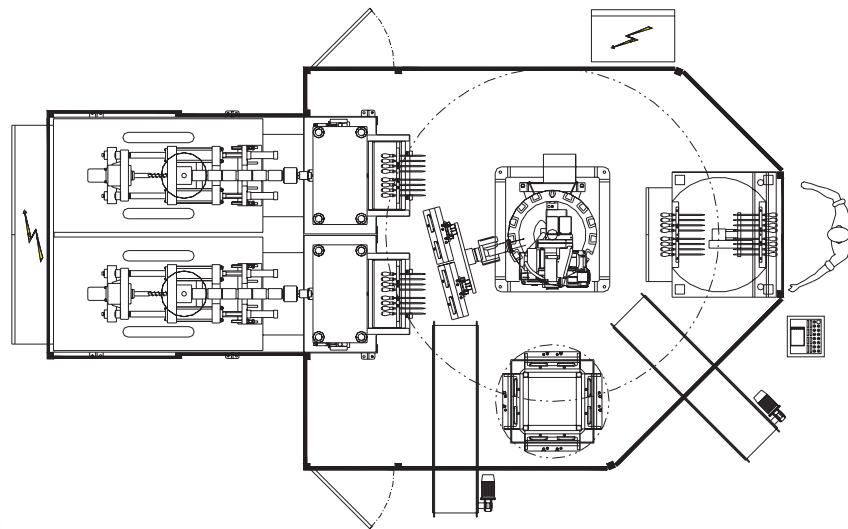

Layout con due "Modulo"
Layout with two "Modulo" machines

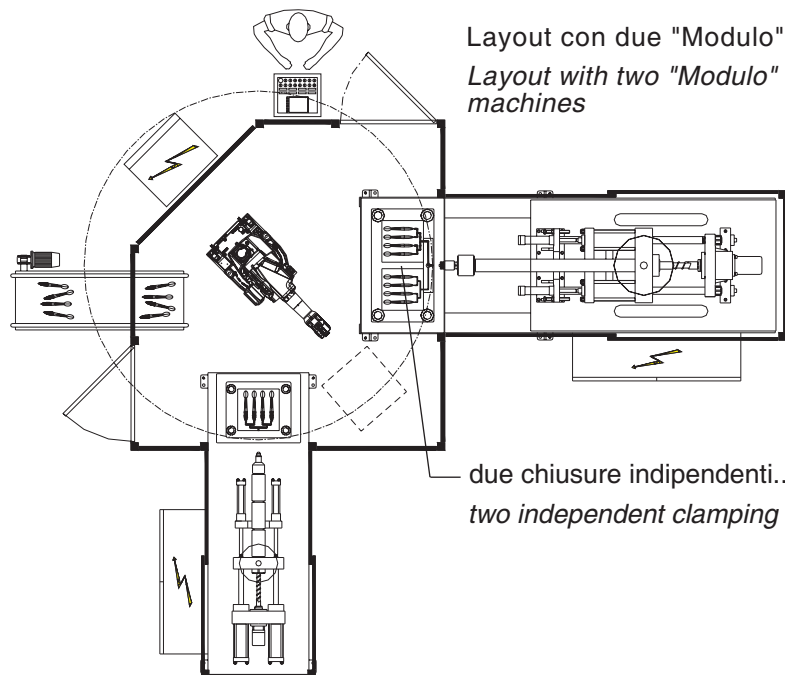

due chiusure indipendenti...
two independent clamping units...

...anche con gruppo iniettore bicomponente shuttle
...also with shuttle co-injection unit

Layout con una "Modulo 2"
Layout with one single "Modulo 2" machine

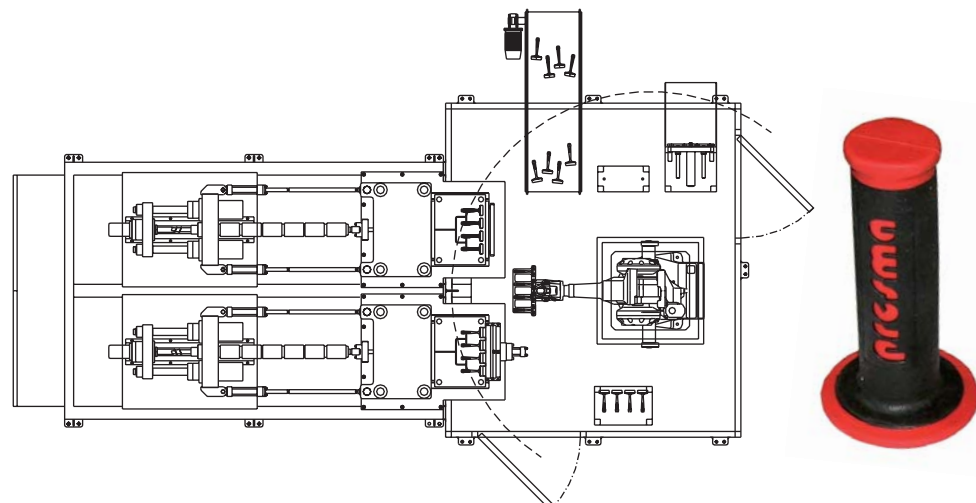

3 COLOURS AND/OR MATERIALS

P3C

Layout con una "Modulo 2" e una "Modulo 1"
Layout with one "Modulo 2" machine and one "Modulo 1" machine

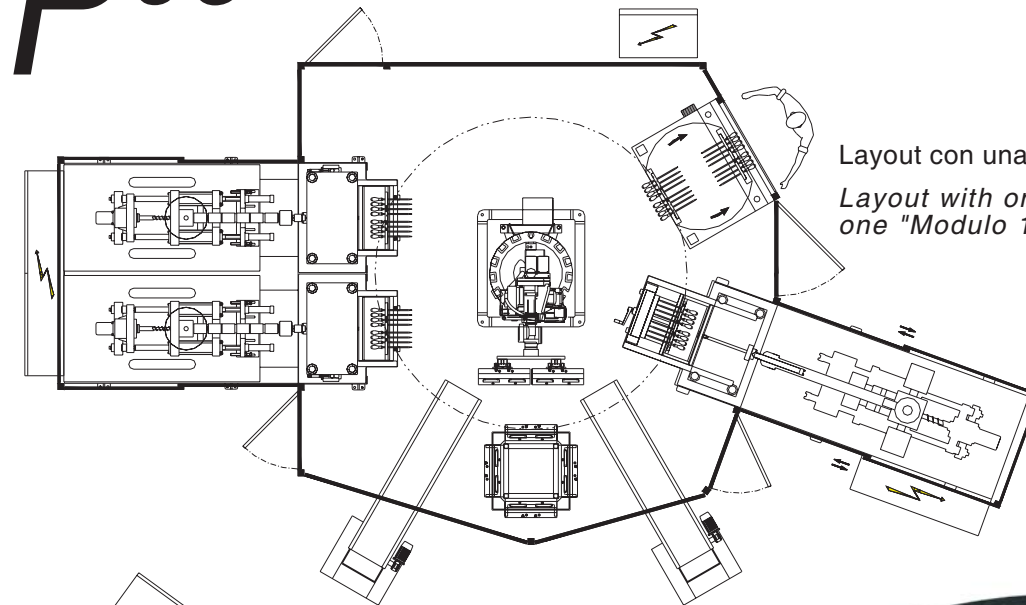

Layout con giostra per carico inserti negli stampi
Layout with carousel for insert positioning in the moulds

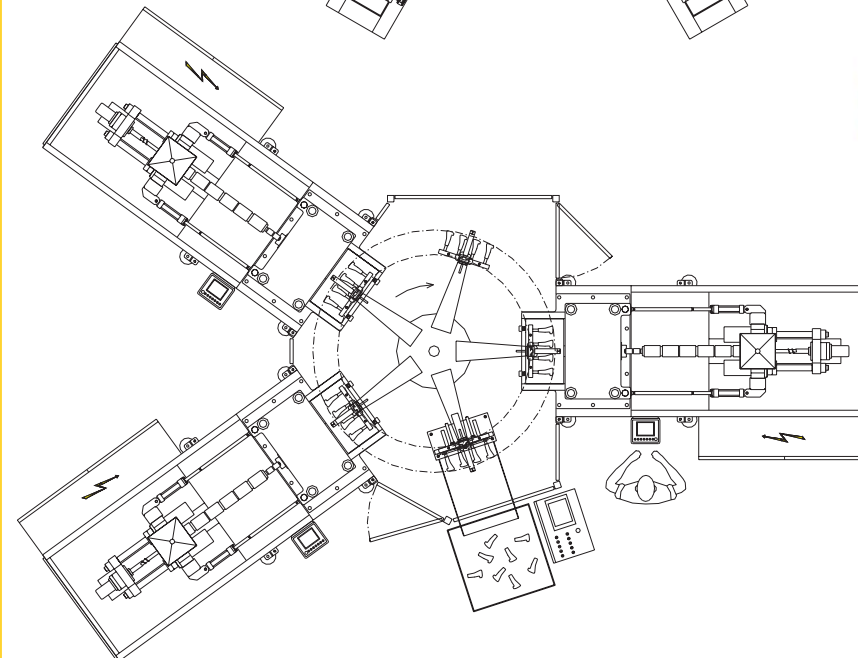

Layout con una "Modulo 2" dotata di 3° gruppo verticale
Layout with one single "Modulo 2" machine equipped with 3.rd injection unit

